

Part No:
BBWS1225 | 40

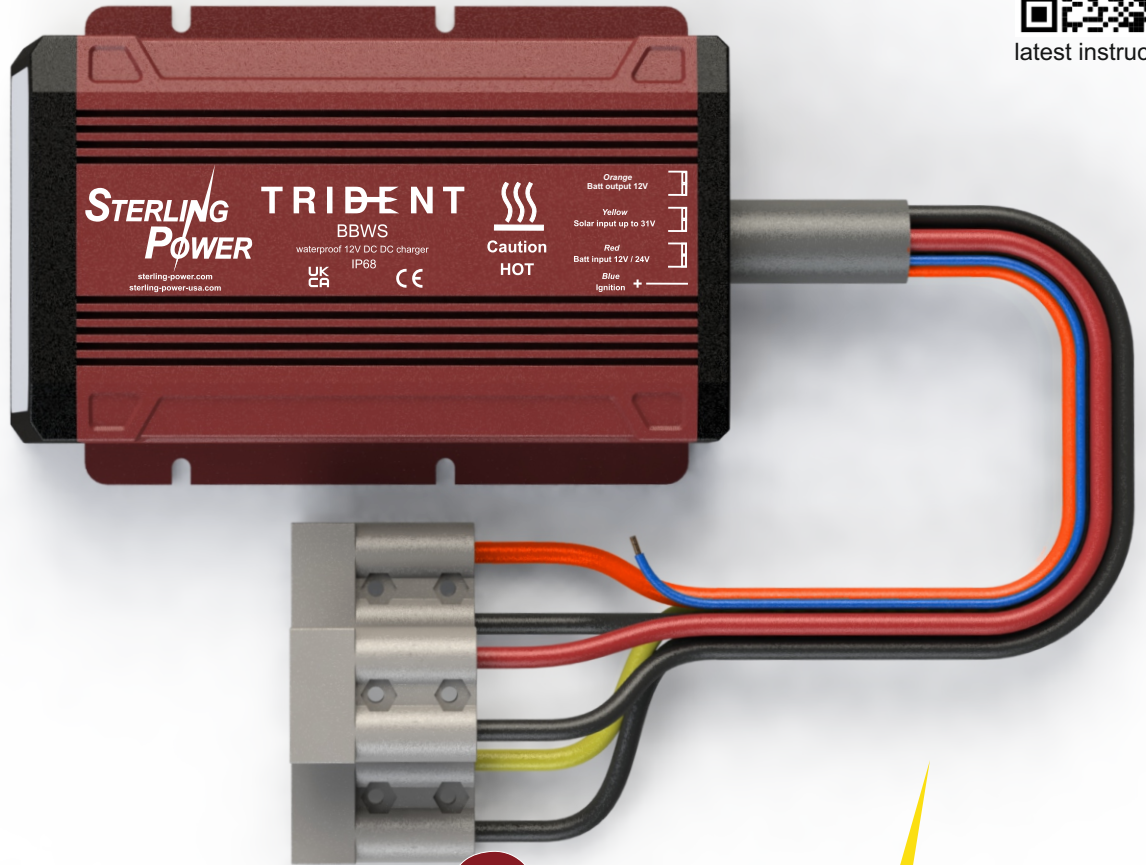

latest instructions



STERLING POWER

Sterling Power Products 12V / 24V to 12V 25A / 40A IP68 Battery to Battery Charger Handbook

BBWS1225 | 40

EURO 6



UK
CA



RoHS
compliant



www.sterling-power.com
www.sterling-power-usa.com

Warranty (2 years return to factory)

Copyright © 2024
Sterling Power
All Rights Reserved

INTRODUCTION TABLE OF CONTENTS

Introduction
 02 Table of Contents | Dimension Drawing
 03 Welcome

Safety and Legal
 04 Legal Guidelines / Warranty Statement
 05 Safety Guidelines

Product Information
 06 Basic Wiring Diagram / Installation Orientation
 07 Annotated diagram of front section of BBWS
 08 Annotated diagram of connector panel
 09 Front digital display functions
 10 Troubleshooting

Dimensions drawing
(not to scale)

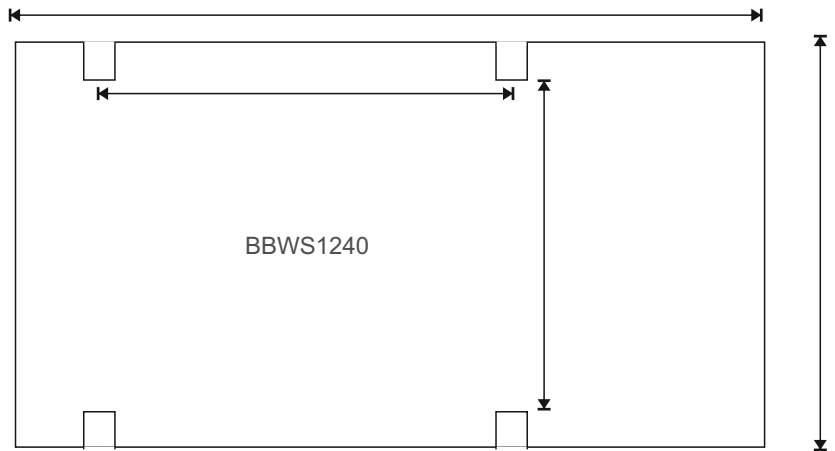
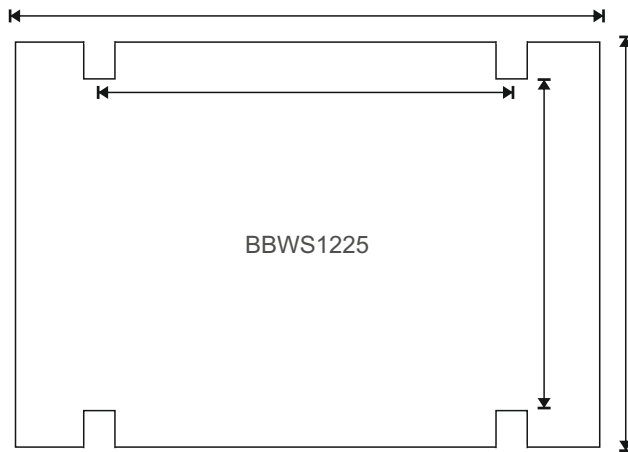

BBWS1225
 Dimensions 153.5mm x 131mm x 40mm
 Weight 2.2Kg

BBWS1240
 Dimensions 191.5mm x 131mm x 40mm
 Weight 2.9Kg



INTRODUCTION WELCOME

Welcome Welcome to the Sterling Power Products Owners Handbook for the product BBWS, the 12V|24V to 12V battery to battery charger (IP68) w/ solar input.

Please take your time to read and fully understand the contents of this Handbook. These guidelines are developed with your safety and the products performance in mind and failure to follow or understand these guidelines may lead to voiding the product warranty or even leading to damage or injury for you or your setup.

If you are unsure of any step or guideline then please consider reaching out to Sterling via our web contact form or our phone service and we shall offer our support.

Thank you for joining the Sterling family and we hope to serve your travels well.

BBWS1225 | 40 This BBWS battery to battery charger is a device typically installed between a starter battery (input) and a house / domestic / service battery (output). The BBWS is designed to charge up your 12V domestic / service / auxiliary battery from the power generated from your alternator, whilst your engine is running. It is designed to work with vehicles (old / new) and (boats old / new). As this device is 25A or 40A rated on the input, we recommend running from an alternator 60A+. This BB charges both lead acid style batteries and lithium batteries. The solar input is good for up to 31V and shall harvest 350W or 550W (model dependent). The BBWS shall simply get power from either solar or power generated from your alternator. It shall tap into where it can get the most power from.

Throughout this manual we will make reference to this product as the 'BBWS'. The term '12V' or '24V' is the nominal voltage, not the specific voltage.

Using this Handbook This manual must be read throughout before installing this electronic device. Do not lose these instructions - keep them safe. The most up to date instructions can be found on sterling-power.com. Please refer to the latest instruction manual before contacting Sterling. At Sterling, we endeavour to include all of the product information that we can think of into the manual.

Installation of the electronic device must be carried out by qualified and trained personnel only. The personnel must be familiar with the locally accepted guidelines and safety measures.

Safety Your safety is Sterling's top priority. Please follow all precautions to keep yourself safe. If you believe your unit requires repair then please contact Sterling or your distributor. Do not attempt to service the unit yourself.

Specifications	BBWS1225 40	
	Input voltage range	9V-31V
	Rated output power	25A 40A ~ 350W 550W
	Rated input current	up to 26A up to 42A
	Quiescent current	<10mA
	Efficiency rating	96% - 98%
	IP rating	IP68
	Self recovering protections:	under voltage protection input over voltage protection output over voltage protection over current protection charge over temperature
	Operational Temperature	-20 Deg C -> 60 DegC
	Approval	CE UKCA E-Marking
Cooling method	Thermostatically Controlled Variable low speed fan	



SAFETY AND LEGAL LEGAL GUIDELINES

Warranty and Terms

Your 100 % satisfaction is our goal. We realise that every customer and circumstance is unique. If you have a problem, question, or comment please do not hesitate to contact us. We welcome you to contact us even after the warranty and return time has passed.

Each product manufactured by Sterling Power comes with at least a 2 year limited factory warranty. Certain Products have a warranty period of time greater than 2 years. Each product is guaranteed against defects in material or workmanship from the date of purchase. At our discretion, we will repair or replace free of charge any defects in material or workmanship that fall within the warranty period of the Sterling Power product. The following conditions do apply:

- The original receipt or proof of purchase must be submitted to claim warranty. If proof cannot be located a warranty is calculated from the date of manufacture.
- Our warranty covers manufacture and material defects. Damages caused by abuse, neglect, accident, alterations and improper use are not covered under our warranty.
- Warranty is null and void if damage occurs due to negligent repairs.
- Customer is responsible for inbound shipping costs of the product to Sterling Power either in the USA or England.
- Sterling Power will ship the repaired or warranty replacement product back to the purchaser at their cost.

If your order was damaged in transit or arrives with an error, please contact us ASAP so we may take care of the matter promptly and at no expense to you. This only applies for shipping which was undertaken by our company and does not apply for shipping organised by yourself. Please do not throw out any shipping or packaging materials. All returns for any reason will require a proof of purchase with the purchase date. The proof of purchase must be sent with the returned shipment. If you have no proof of purchase call the vendor who supplied you and acquire the appropriate documentation.

To make a claim under warranty, call our customer care check telephone numbers on www.sterling-power.com or www.sterling-power-usa.com. We will make the best effort to repair or replace the product, if found to be defective within the terms of the warranty. Sterling Power will ship the repaired or warranty replacement product back to the purchaser, if purchased from us.

Please review the documentation included with your purchase. Our warranty only covers orders purchased from Sterling Power. We cannot accept warranty claims from any other Sterling Power distributor. Purchase or other acceptance of the product shall be on the condition and agreement that Sterling Power USA LLC and Sterling Power LTD shall not be liable for incidental or consequential damages of any kind. Some states may not allow the exclusion or limitation of consequential damages, so, the above limitations may not apply to you. Additionally, Sterling Power USA and Sterling Power LTD neither assumes nor authorizes any person for any obligation or liability in connection with the sale of this product. This warranty is made in lieu of all other obligations or liabilities. This warranty provides you specific legal rights and you may also have other rights, which vary from state to state. This warranty is in lieu of all other, expressed or implied.

Copyright and Plagiarism

Copyright © 2024 Sterling Power. All rights reserved. Reproduction, transfer, distribution or storage of part or all of the contents of this document is strictly prohibited. If you wish to use all of this document, or excerpts from it, Sterling Power must be contacted.

Liability

Sterling Power can not accept liability for:

- consequential damage due to use of this device
- possible errors in the manuals and the results thereof

Device Modification

Please do not modify the device unless you have been instructed to do so by Sterling Power directly. Product modification shall be done at Sterling when needed. Warranty shall be voided if personal attempts are made to modify the device without Sterling's approval.



STERLING
POWER

SAFETY AND LEGAL SAFETY GUIDELINES

Product Guidelines Your Sterling Power product should only be utilised for its designated purpose. Use the Battery to Battery Charger ONLY :

- For DC to DC power conversion
- With fuses protecting both the input and output DC cables
- In a well ventilated, dry, dust-free and condensation free environment
- When the Owners Handbook has been read and wholly understood

Transport and Storage Ensure that the mains supply and battery leads are disconnected before transporting or moving the unit. No liability can be accepted for damage in transit once equipment has been unpackaged. Store the product in a dry environment, between -20°C to 60°C .

Refer to the battery manufacturer's manual for information on transportation, stowage, charge rates, recharging and battery disposal for your battery care.

General Maintenance The device must be switched off during maintenance and all cables removed from the direct feed to or from the unit. It must also be protected against unexpected switching off. Remove battery connections and ensure unit is off. If repair is required, only use original parts. Unauthorised attempts to repair Sterling units will lead to the warranty being voided. Only someone with adequate understanding of electronics and the unit itself should attempt a repair.

Ensure your connections are good and clean and aim to protect your unit from humidity and water ingress.

Safety Precautions Electrical appliances can be heavy. Please do not lift heavy units unassisted. Ensure that your product is correct for your intent. 12V battery. Incorrect use can lead to damage. Orientation is not critical to unit function, however may affect water ingress rating. Install device in a well ventilated space for cooling purposes. Do not expose the unit to snow, rain, water, spray, condensation, pollution etc, unless it is a waterproof unit. If it is a waterproof unit, only expose it to situations it is correctly rated for. Do not cover or obstruct the ventilation. Device connects to common negative. Common negatives must be earthed. In case of fire, use fire extinguisher equipment suitable for electrical fires. Avoid all possibilities of reverse polarity or short circuiting. Check cabling and connections frequently and ensure the connections are sufficient. Always protect DC cabling with the appropriate fusing. Ensure the unit is adequately and safely mounted to prevent displacement and damage. Always use a professional to install electrical products. Ensure the product is correctly set up for your battery. Keep out of reach of children

WARNING : CROSS VOLTAGE THRESHOLD BATTERY TO BATTERY CHARGERS MUST BE INSTALLED WITH CARE A COMMON NEGATIVE IS PARAMOUNT TO OPERATION, HOWEVER, BE INCREDIBLY CAREFUL NOT TO SHORT CIRCUIT OR REVERSE POLARITY ANY EQUIPMENT OR CABLE.

All electrical appliances carry the risk of electrical shock. This equipment is designed to be used in combination with a permanent energy source (the battery). Always isolate the DC before performing any maintenance or inspection.

Do NOT remove the panelling to inspect the internals unless expressly told to by Sterling. This is not a product designed to be user-serviced.

Do NOT use the device in situations where there is danger of gas / dust / vapour explosions, or around potentially flammable produce.



PRODUCT INFORMATION SIMPLE WIRING DIAGRAM

Basic installation diagram

Here, we hope to provide a very basic installation diagram for the vast majority of installers to follow.

If a process is not mentioned here, the chances are that it is not a pre-requisite to get the BBWS to function.

The default charging profile is a standard sealed lead acid charging profile of 14.4V and 13.8V float.

The BBWS also allows charging of lithium batteries.

12V ignition signal, required for Euro 6 / Smart alternator use.

Ignition gives a binary on / off style signal to control the BBWS.

If ignition signal is not used, the BB needs to see 13.5V on the input terminal to begin charging the output battery. When the input then drops below 12.8V the BB will stop charging.

Recommended installation orientation

The BBWS can be mounted in any orientation.

There is no wattage limit. BBWS shall simply harvest **350W** or **550W** (model dependent)

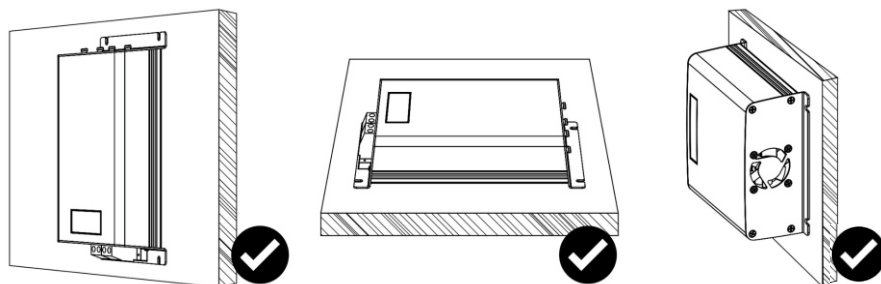
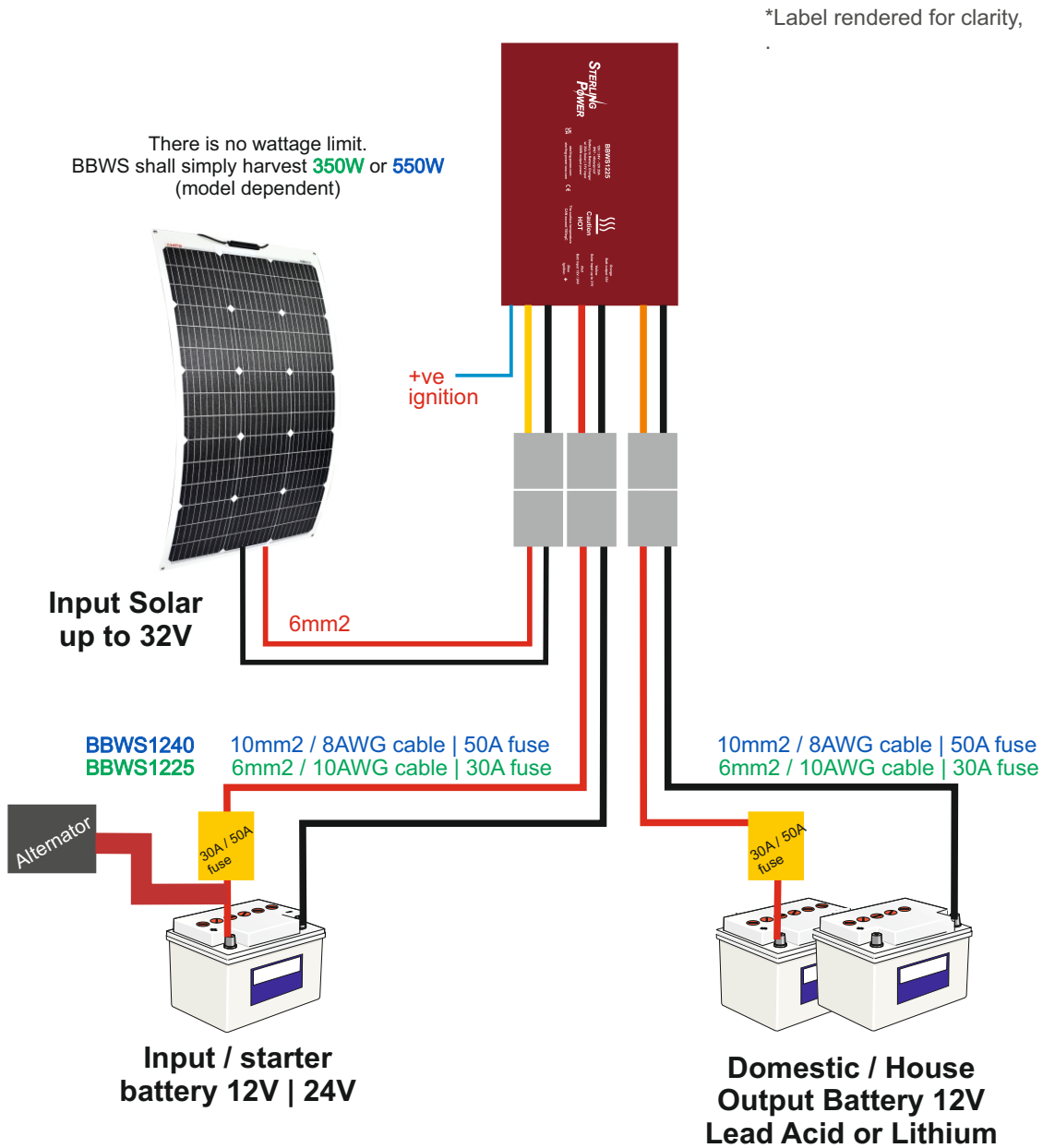

PRODUCT INFORMATION UNDERSTANDING YOUR BBWS

BBWS Diagram

The BBWS has 4x mounting feet, 2x on each side.

*Label rendered for clarity,

As the BBWS has no fans to keep cool, the entire BBWS case acts as a heat sink and is prone to getting hot. The surface temperature can exceed 70 DegC.

Display panel. The facia of the BBWS is comprised of multiple LEDs that tell the user where the power is coming from 'Power source' and what battery type the charger is in.

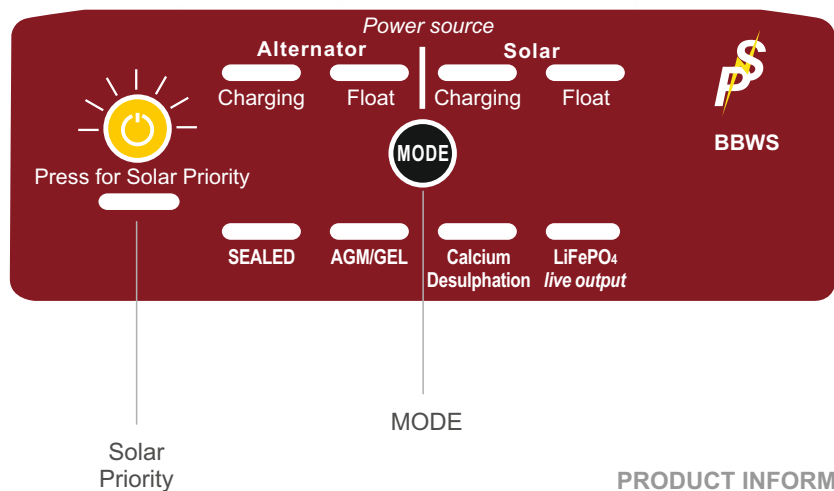
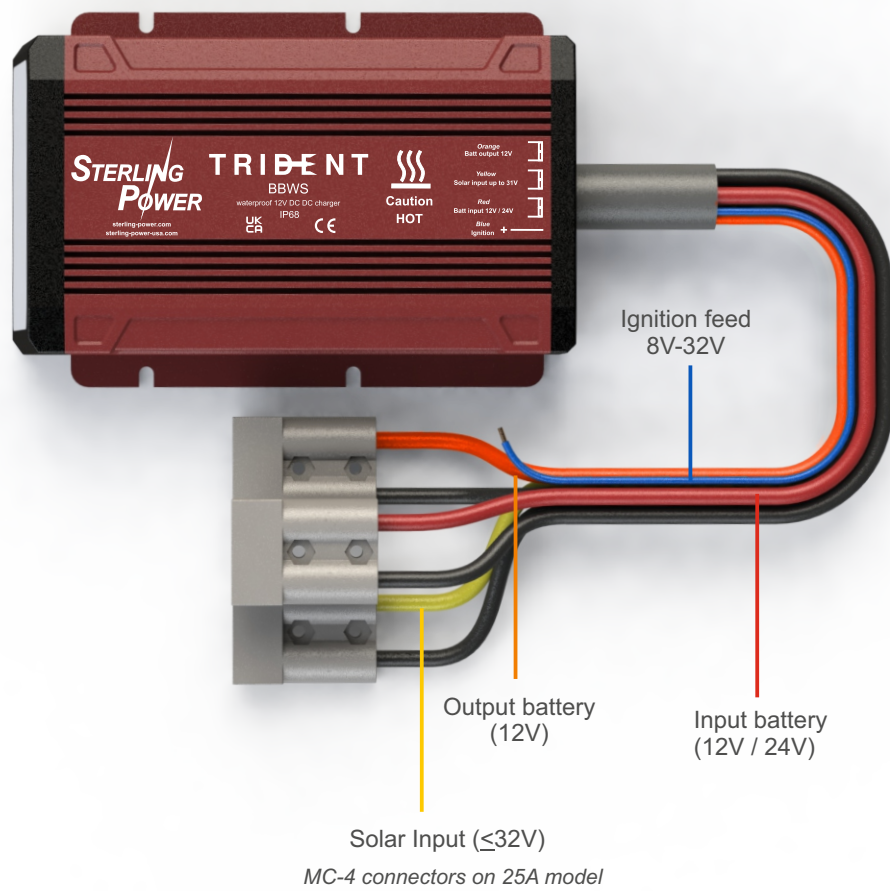



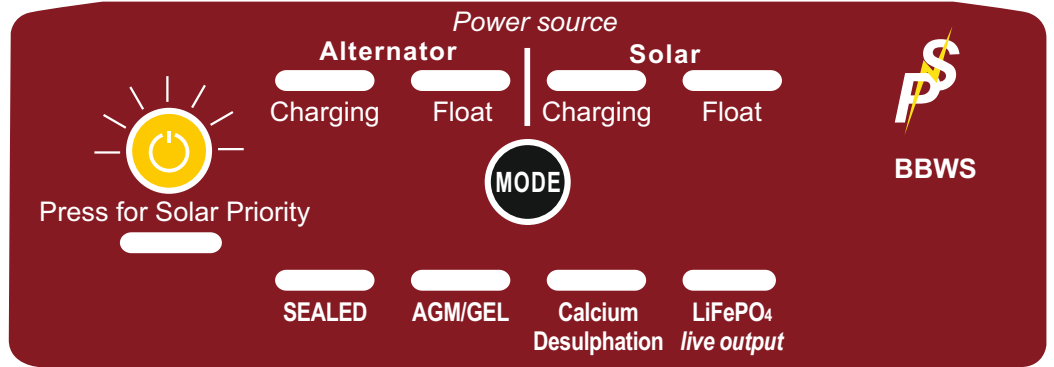

PRODUCT INFORMATION UNDERSTANDING YOUR BBWS

BBWS facia

*Label rendered for clarity,



MODE To change the battery type. Simply press the MODE button for 3 seconds then release. Then simply press the MODE button again to move the LED to the desired battery type. Table, as below.

LED	Battery Type	Absorptions (V)	Float (V)
 SEALED	Sealed LA	14.4V	13.6V
 AGM / GEL	AGM / Gel	14.1V	13.6V
 Calcium / Desulphation	Calcium	15.3V	13.6V
 LiFePO ₄ <i>Live Output</i>	Lithium	14.4V	

Solar Priority Press and hold for 3 seconds to turn on / off. LED illuminates when activated.

Solar priority, as the name suggests, harvests the power from solar input as a priority. This maybe ideal if you have a sunny day and your solar panels are at maximum performance. For example, if you have 550W+ of solar panel connected to the 31V solar input of the BBWS1240 and the sun is out you may wish for the BBWS to use all of the available power from the solar, rather than from your alternator / fuel. The amount of fuel saved could be surprising. 550W is under 1 horsepower. However, you require about 1.5 - 2 horsepower of your engine to generate 550W at your alternator. This, over a long drive or weeks of nice weather could result in several £/\$ shaved off your fuel bill.

If Solar priority is turned off, the BBWS shall simply get power from where it can. When the engine is running it shall get power from your alternator. When your engine is off it shall harness power from the solar input.

Troubleshooting & Faults

Troubleshoot - checks to ensure the BB is installed correctly and receiving the correct input and output voltages.

Firstly, ensure the BBWS is wired up correctly. Ensure negatives are common and the BB charger's negative is connected to the starter battery's negative - avoid connecting to chassis negative. Voltages between common negatives should be ~0V.

Secondly, to test the BB, remove (or turn off) any secondary charging source like AC to DC battery chargers or solar chargers going to the battery banks. Leave the primary charger connected (alternator) - ensure alternator is working. We also recommend turning off any loads (inverters etc.).

How to test if the BB is charging:

With engine running (alternator charging), what is the voltage on the input terminal of the BB? What is the voltage on the output terminal of the BB? Measure these voltages at the BB's terminals, not at the batteries terminals.

By default, the BB requires 13.2V+ to turn on and get going. If you are getting alternator voltage at the input terminal (~14V) and 14V+ on the output terminal the chances are your BB is working fine. If little to no current is passing through the charger at these voltages then the batteries are either full or they are duff. If the output voltage is between 13V-14V (but rising) then you could have a situation where the output batteries were very low in charge (or large in capacity) and the charger shall be charging at maximum current. Provided this output voltage continues rising the BB is charging.

If your output voltage is less than 13V and your input voltage is healthy, it could be three things:

- 1) You have a large load on your output bank - turn load off.
- 2) The BB may have enter a fault state an stopped charging.
- 3) The BB is not working / failed.

If your input voltage is less than 13V, it could be several things:

Automotive: Your alternator's voltage is at less than 13V (the alt. is in regenerative braking mode - sometimes expected on modern Euro 5/6+ engines) - take vehicle for drive and measure alternator's voltage and set up the BB to suit these needs. All vehicle manufactures have their own software / characteristics for regen. braking. Resort to running ignition signal to BB to ensure BB operates irrespective to fluctuating input voltage.





Automotive or Marine: If your alternator's voltage is ~14V then check continuity between the alternator's B+ terminal and the starter battery. If you are getting ~14V on starter battery then check continuity between starter battery and BB input terminal.

Automotive or Marine: If your alternator's voltage is 0-13V (starter battery voltage) then alternator may have failed. Or, requires increase rpm of engine, possible belt slip.

Is your output voltage slightly higher or lower than expected - even with no loads / chargers on?

Check if you have the temperature sensor connected. If so, no problems leaving it there, it is simply voltage compensating for when the temperature at the sensor is lower or higher than the benchmark 20DegC (69F). If lower, then the voltage shall rise and vice versa. The further from 20DegC in either direction leads to proportional increase or decrease in the voltage.

If the voltage at your output battery is 0.3V lower (or more) than at the output of the BB - this is likely due to poor / thin cabling. And / or, due to voltage drop across fuses / fuse holder / isolation switch / relay / diode etc.. between the output of the BB and your output battery. Beef up the cable, clean connections, ensure connections are as tight as possible, remove unnecessary devices (such as isolation switches, relays or diodes) - these are really not required here.

LED	Fault	Suggested solution	Recovery Condition
 Alternator	Low or high input voltage from input battery.	Check voltage at the starter battery / voltage going to the 'input battery'.	If solved, automatic recovery
 Solar	Low or high input voltage from the solar input	Check voltage at the solar input from the solar panel	If solved, automatic recovery
 Battery Type	High output voltage at the 12V output battery	Check output battery voltage above 6V and below 16V.	If solved, automatic recovery
 Alternator  Solar	Over temperature	Let the unit cool down. Place in a better ventilated area.	

