

VAN MASTER VMGWL139



VMGWL139



SPECIFICATIONS

- MULTI VOLTAGE INPUT 10-30VDC.
- 8 X 1.5W LEDS.
- FLOOD BEAM.
- LUMEN OUTPUT: RAW: 1200:LM | EFFECTIVE: 900LM.
- LED COLOUR: WHITE.
- CURRENT CONSUMPTION: 0.8A 12V, 0.4A 24V.
- SUPPLIED WITH STAINLESS STEEL MOUNTING BRACKET.
- WATER AND VIBRATION RESISTANT.
- REVERSE POLARITY PROTECTION.
- WARRANTY: 2 YEARS.

THE VAN MASTER WORK LIGHT RANGE OFFERS WORK LAMP SOLUTIONS AVAILABLE TO SUIT ALL APPLICATIONS AND BUDGETS.

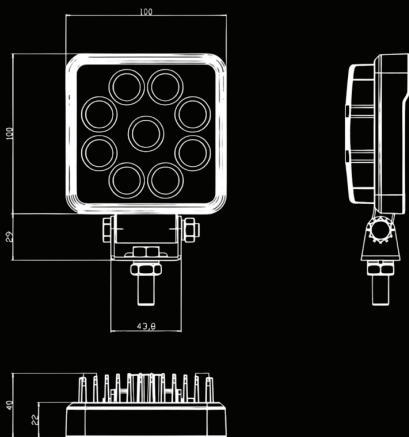

DIMENSIONS:

W:100 X H:100 X D:40MM. HEIGHT WITH BRACKET: 129MM.

APPROVALS:

CE, E-MARKED, ECE R10; R23.
WATERPROOF RATING OF IP67 + IP69K.