

3 MOUNTING OPTIONS AVAILABLE:

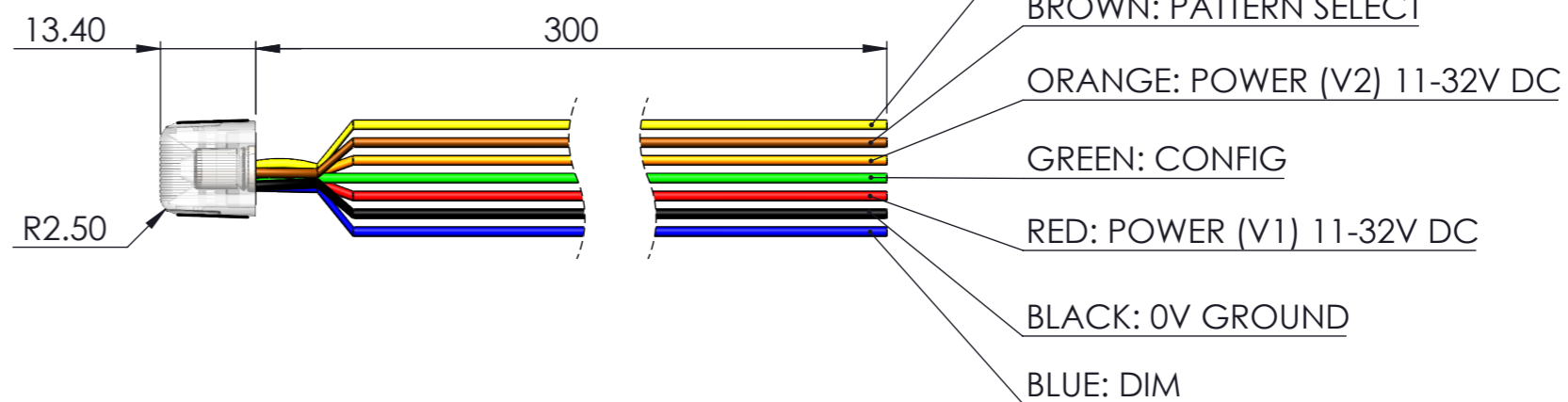
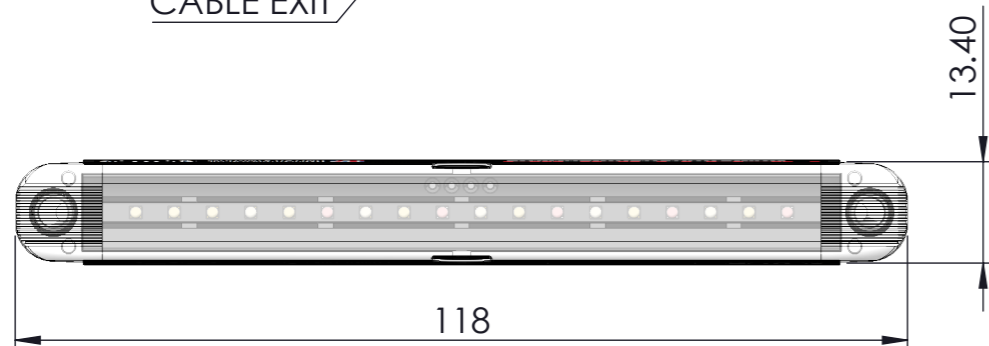
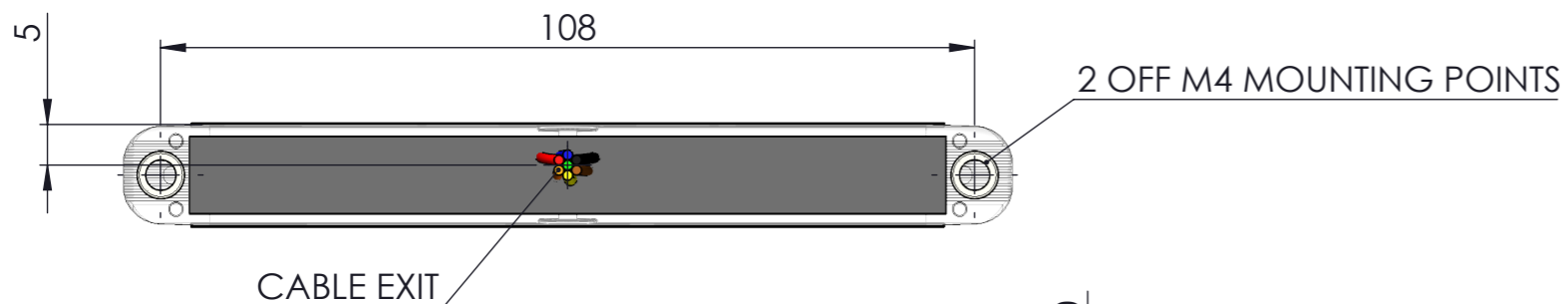
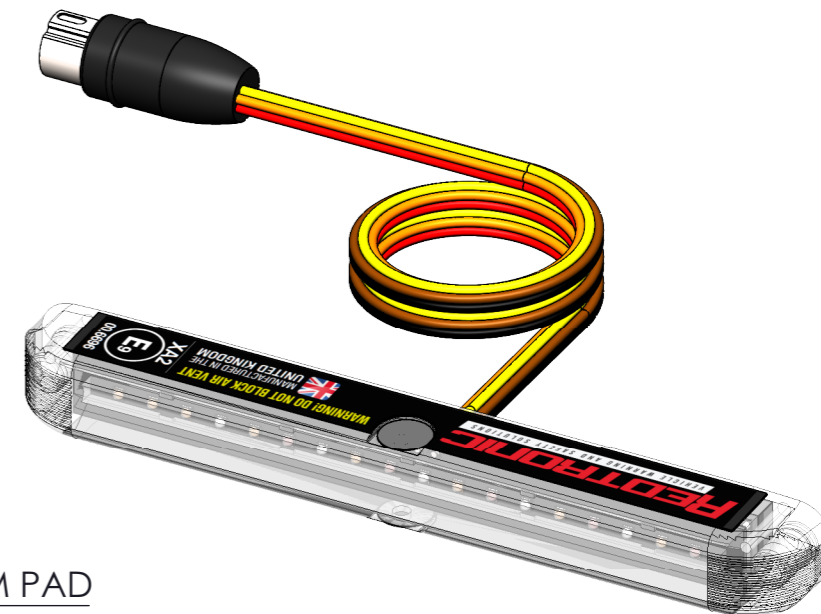
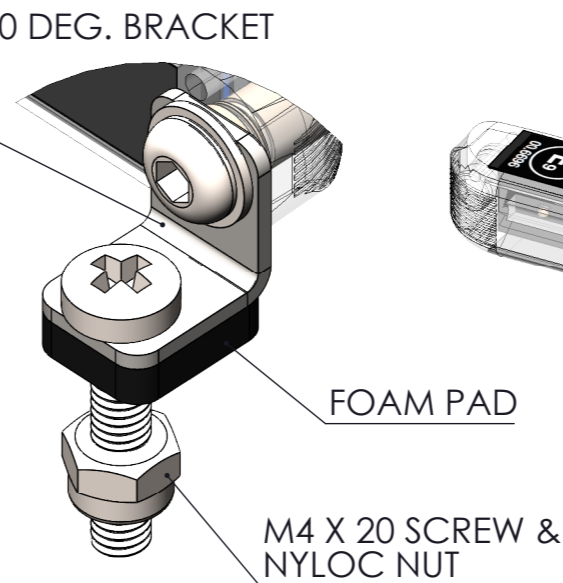
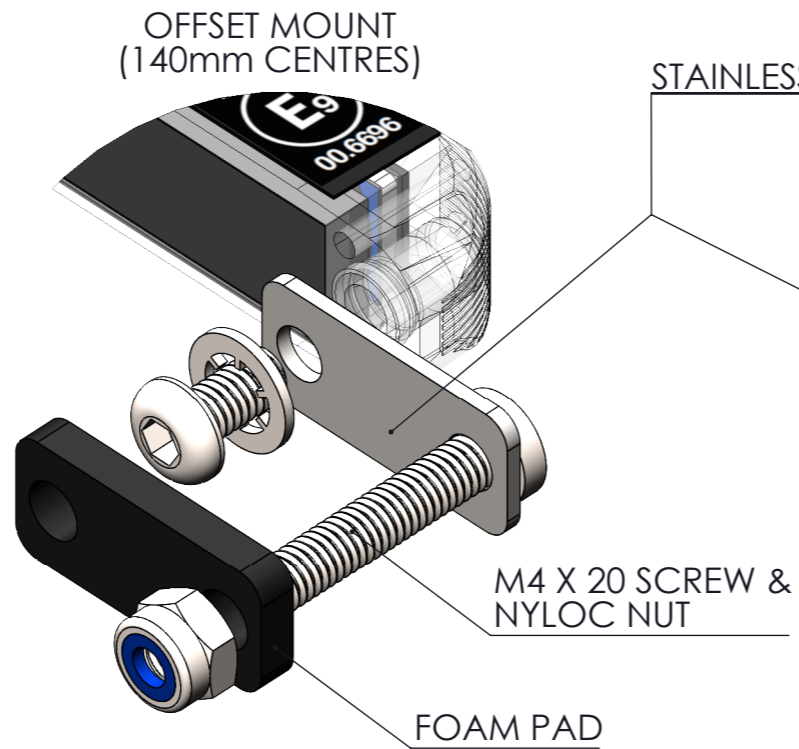
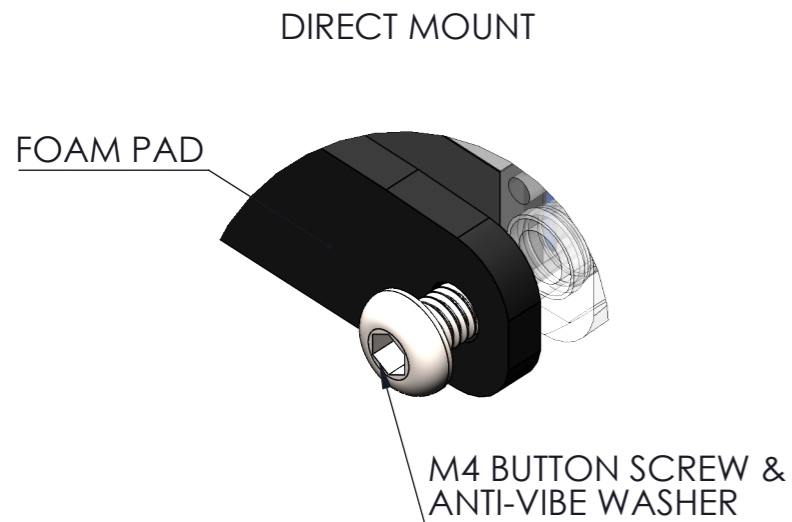

THIS DRAWING IS CONFIDENTIAL AND IS THE EXCLUSIVE PROPERTY OF REDTRONIC LTD. NO UNAUTHORISED USE, COPY OR DISCLOSURE OF THE DRAWING IS TO BE MADE AND IT IS TO BE RETURNED WHENEVER REQUIRED.

PROJECTION	SCALE 1:1
	DRAWN BY WJO
IF IN DOUBT ASK	DATE 20/04/2022
A3	WEIGHT 22.17 g

UNLESS STATED	MATERIAL
DIMENSIONS MM	AS PARTS
TOL. LINEAR ±0.3	FINISH
TOL. DIAGONAL ±0.5	
TOL. ANGULAR ±0.5	

MATERIAL	AS PARTS
FINISH	CLEAR GLOSS

REDTRONIC VEHICLE WARNING AND SAFETY SOLUTIONS	
DESCRIPTION INFINITY US6 GRILLE LIGHT	
SHEET. 1 OF 2	DWG NO DIFX-006--- REV C